



(12) **United States Patent**
Zias et al.

(10) **Patent No.:** **US 7,047,814 B2**
(45) **Date of Patent:** **May 23, 2006**

(54) **MICRO-ELECTROMECHANICAL SENSOR**

(75) Inventors: **Art Zias**, Los Altos, CA (US); **Phil Mauger**, Santa Clara, CA (US); **Sean Cahill**, Palo Alto, CA (US); **Norm Nystrom**, Saratoga, CA (US); **Albert K. Henning**, Palo Alto, CA (US)

(73) Assignee: **Redwood Microsystems, Inc.**, Menlo Park, CA (US)

(*) Notice: Subject to any disclaimer, the term of this patent is extended or adjusted under 35 U.S.C. 154(b) by 0 days.

(21) Appl. No.: **10/198,304**

(22) Filed: **Jul. 17, 2002**

(65) **Prior Publication Data**

US 2003/0072127 A1 Apr. 17, 2003

Related U.S. Application Data

(60) Provisional application No. 60/306,175, filed on Jul. 17, 2001.

(51) **Int. Cl.**
G01L 9/12 (2006.01)

(52) **U.S. Cl.** **73/718**

(58) **Field of Classification Search** **73/718, 73/724; 361/283.4**
See application file for complete search history.

(56) **References Cited**

U.S. PATENT DOCUMENTS

- 4,178,621 A 12/1979 Simonelic et al.
- 4,345,299 A * 8/1982 Ho 361/283.4
- 4,358,814 A 11/1982 Lee et al.
- 4,599,888 A 7/1986 Hufton et al.
- 4,948,174 A 8/1990 Thomson et al.
- 4,996,627 A 2/1991 Zias et al.
- 5,121,945 A 6/1992 Thomson et al.

- 5,274,567 A 12/1993 Kallin et al.
- 5,357,806 A 10/1994 Dennis et al.
- 5,369,544 A 11/1994 Mastrangelo
- 5,528,452 A 6/1996 Ko
- 5,531,128 A 7/1996 Ryhänen
- 5,585,311 A 12/1996 Ko
- 5,757,608 A 5/1998 Bernot et al.
- 5,936,163 A 8/1999 Greathouse
- 6,006,607 A 12/1999 Bryzek et al.
- 6,122,973 A * 9/2000 Nomura et al. 73/724
- 6,151,967 A 11/2000 McIntosh et al.
- 6,211,558 B1 4/2001 Ismail et al.
- 6,252,759 B1 6/2001 Lange et al.
- 6,257,068 B1 7/2001 Briefer et al.
- 6,267,009 B1 7/2001 Drewes et al.
- 6,355,534 B1 3/2002 Cheng et al.
- 6,465,271 B1 10/2002 Ko et al.
- 2001/0008478 A1 7/2001 McIntosh et al.
- 2001/0020320 A1 9/2001 McIntosh et al.
- 2001/0033048 A1 10/2001 Kamifuku
- 2001/0047689 A1 12/2001 McIntosh
- 2003/0019299 A1 1/2003 Horie et al.

* cited by examiner

Primary Examiner—William Oen

(74) *Attorney, Agent, or Firm*—Morgan Lewis & Bockius LLP

(57) **ABSTRACT**

A force or pressure transducer is disclosed. In one embodiment, the transducer has a substrate, a dielectric material disposed on the substrate, a spacing member disposed on the dielectric material, and a resilient element disposed on the dielectric material and the spacing member. A portion of the resilient element is separated from the dielectric material, and a portion of the resilient element is in contact with the dielectric material. The contact area between the resilient element and the dielectric material varies in response to movement of the resilient element. Changes in the contact area alter the capacitance of the transducer, which can be measured by circuit means.

43 Claims, 14 Drawing Sheets

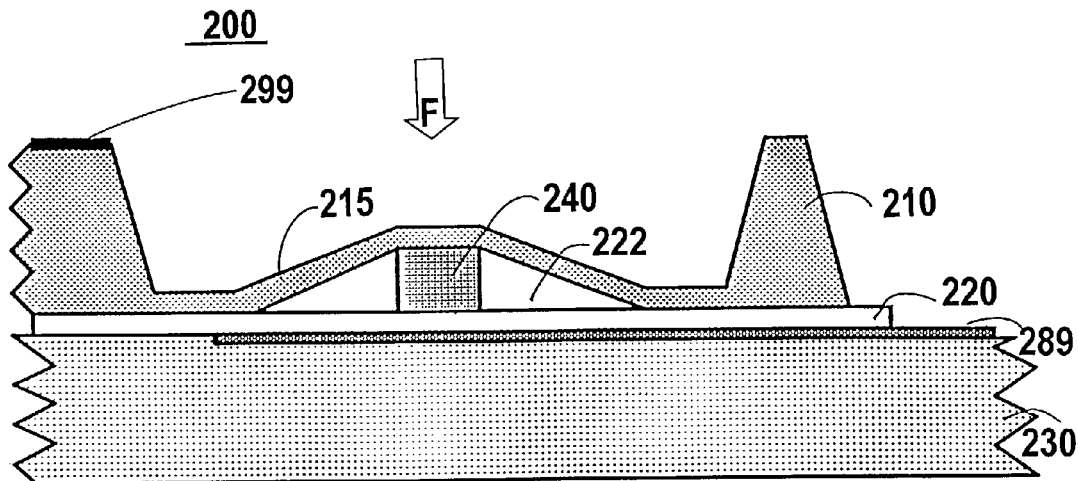

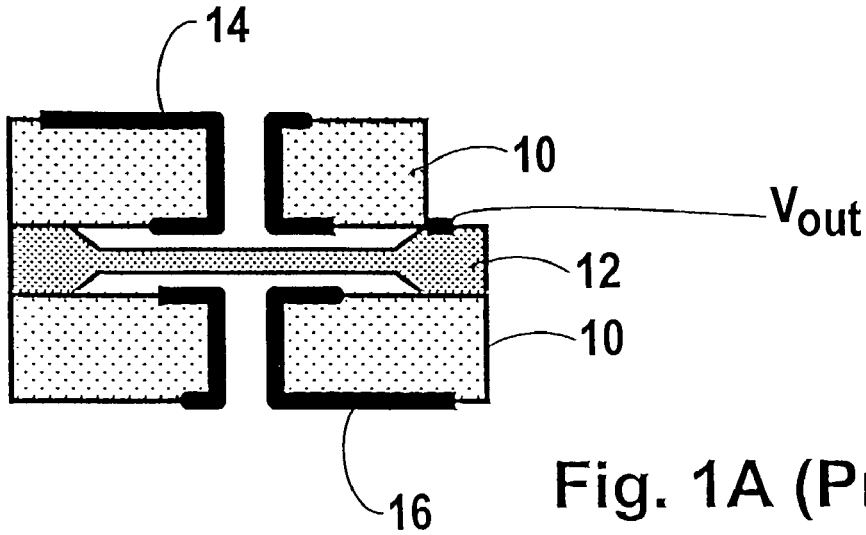

Fig. 1A (Prior Art)

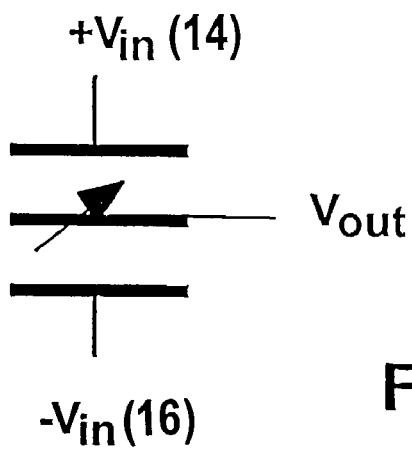

Fig. 1B (Prior Art)

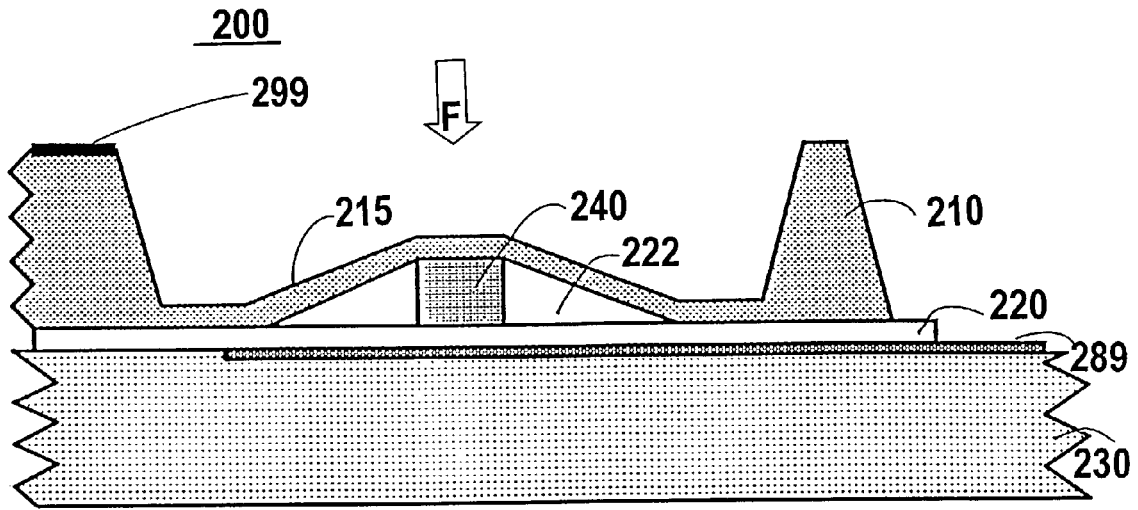

Fig. 2

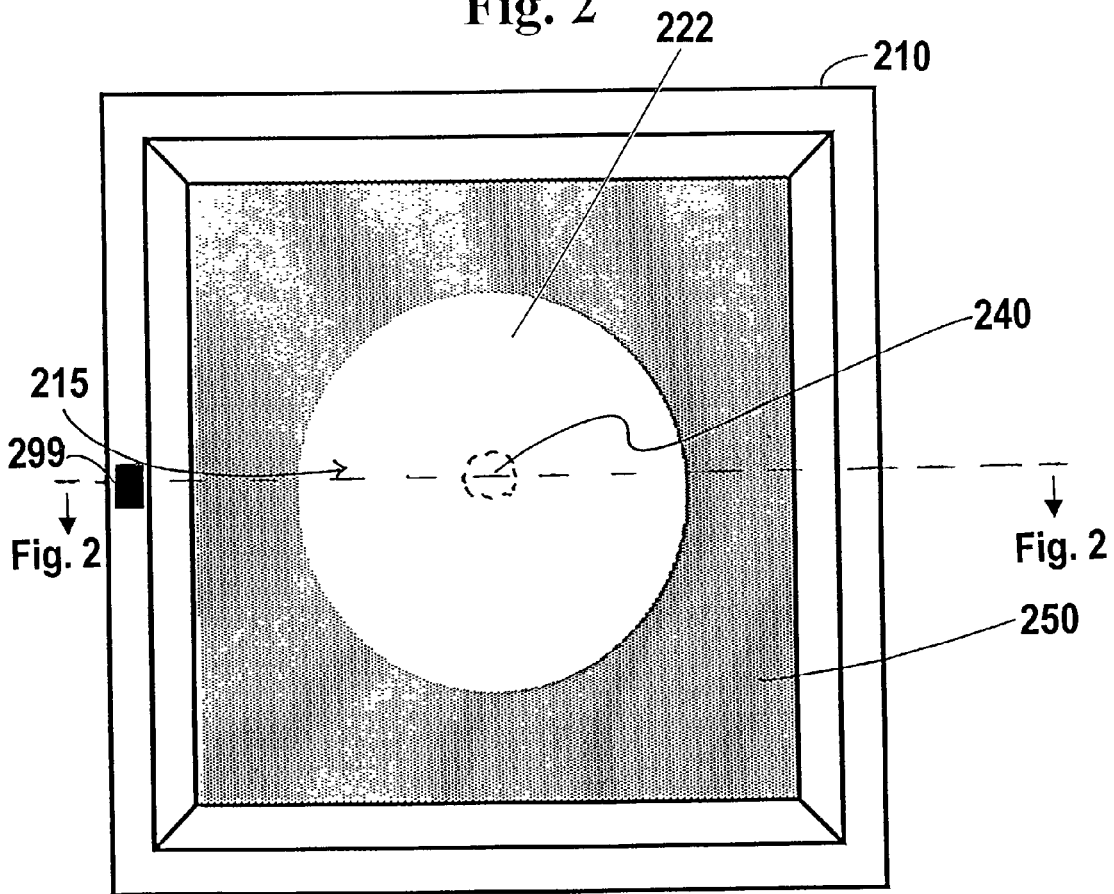

Fig. 3

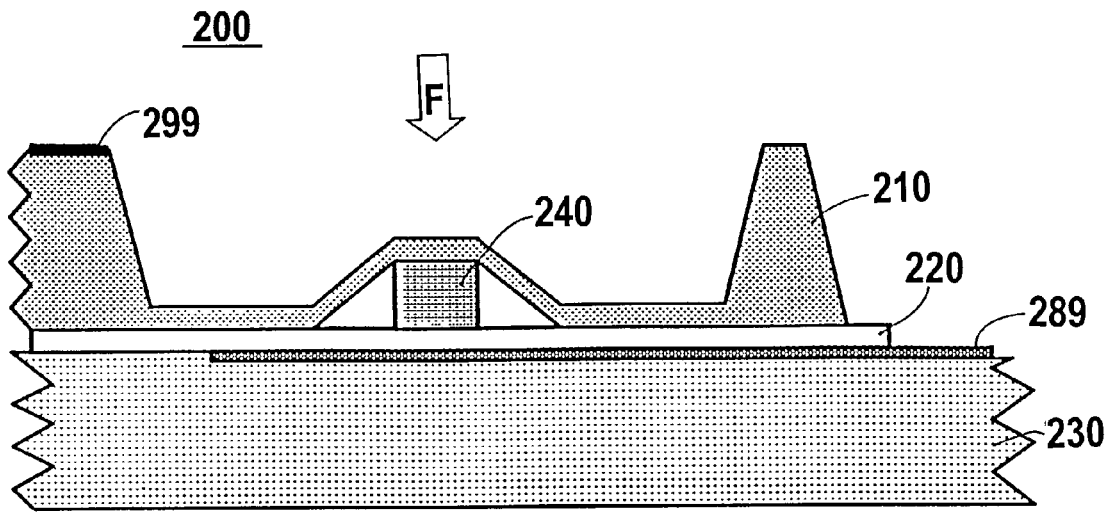

Fig. 4

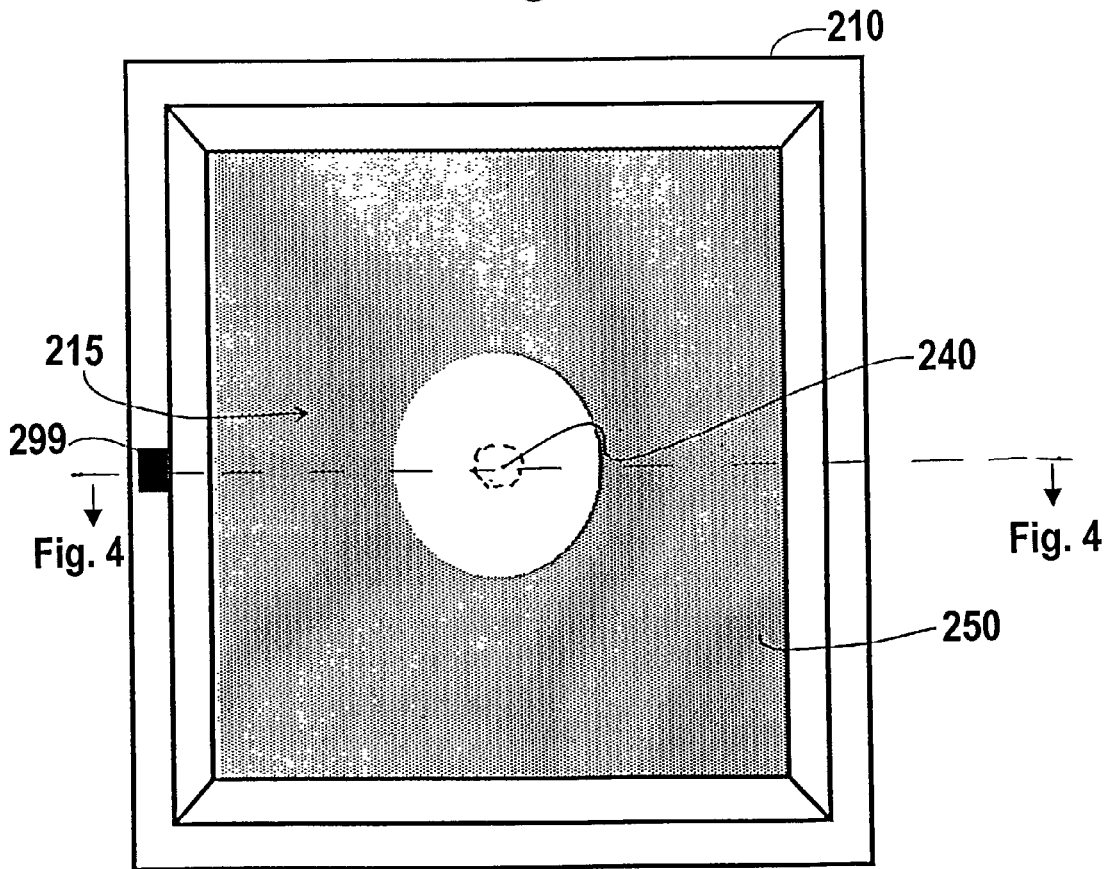

Fig. 5

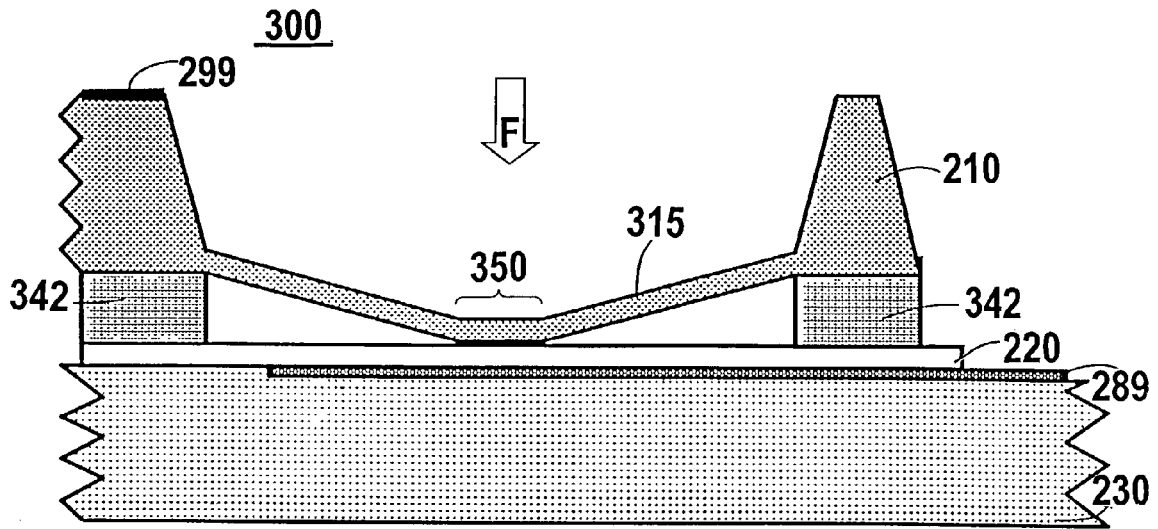

Fig. 6

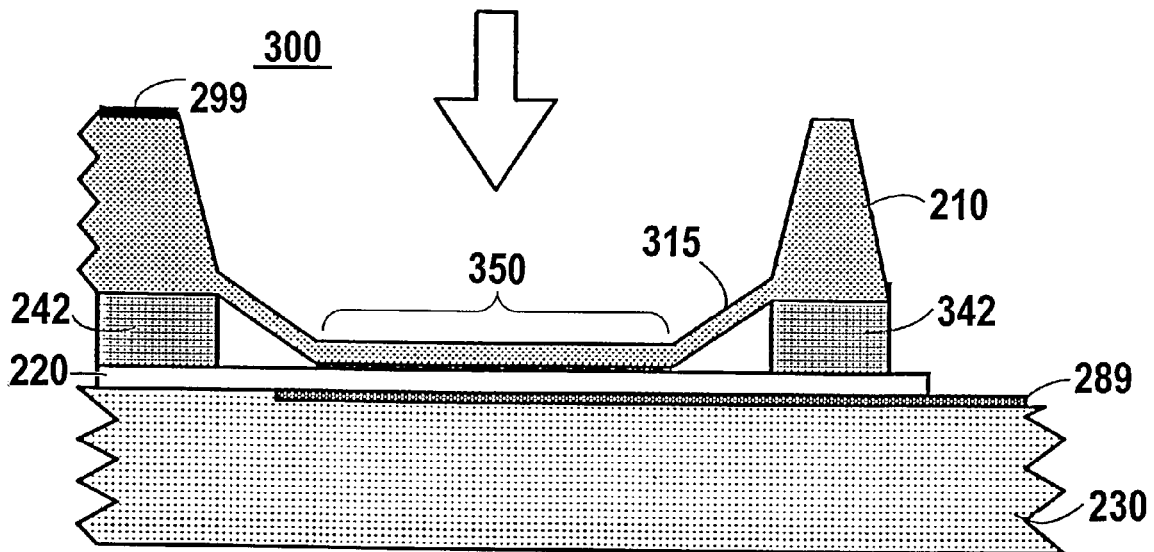

Fig. 7

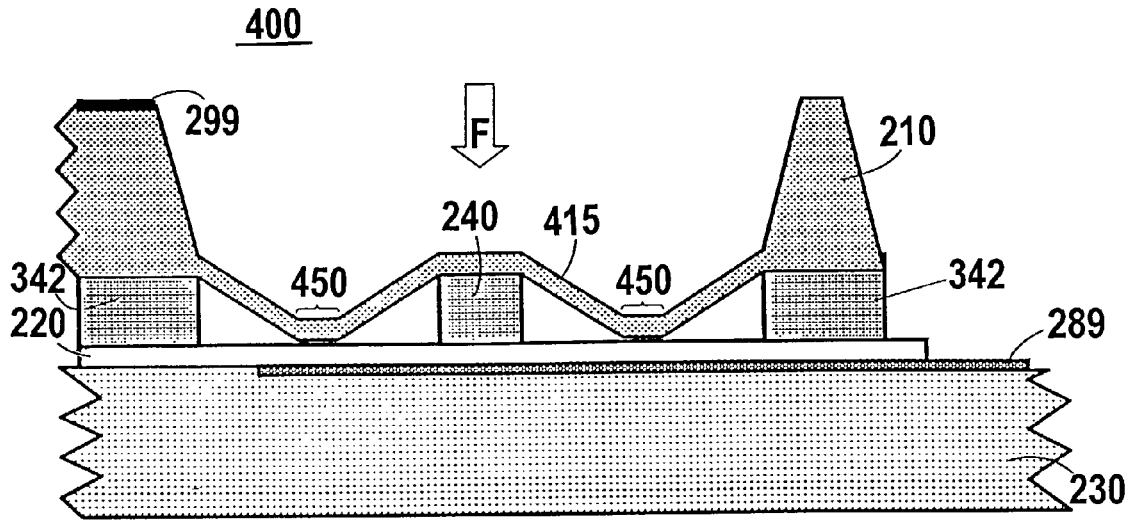

Fig. 8

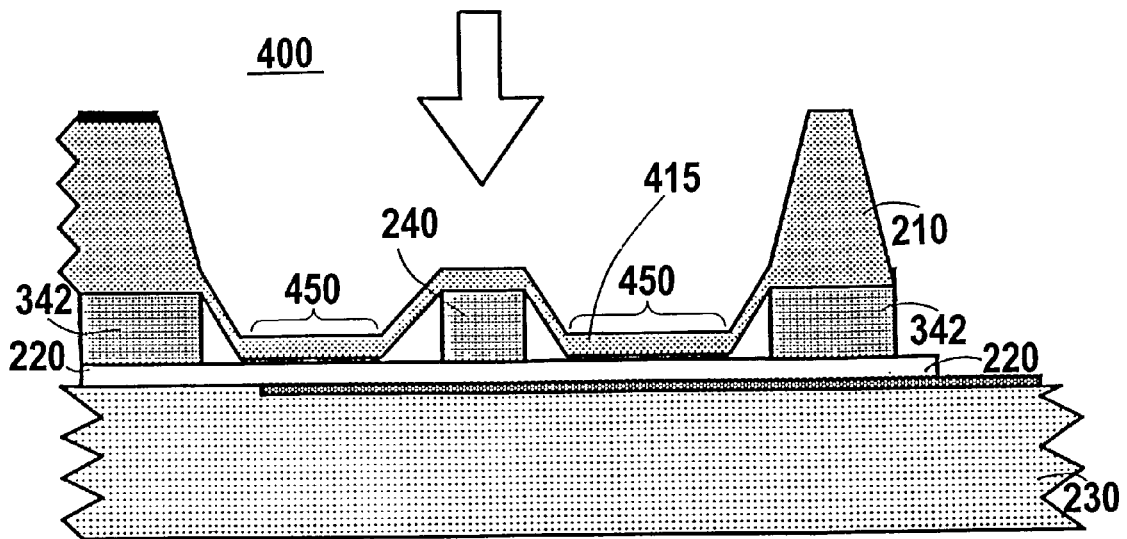

Fig. 9

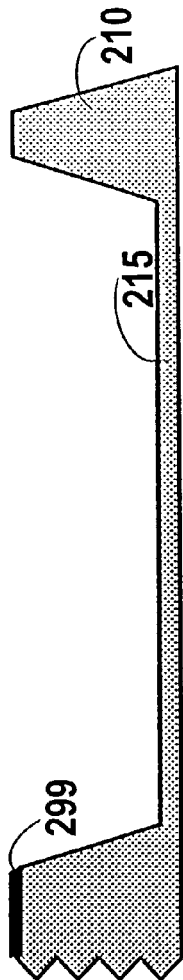
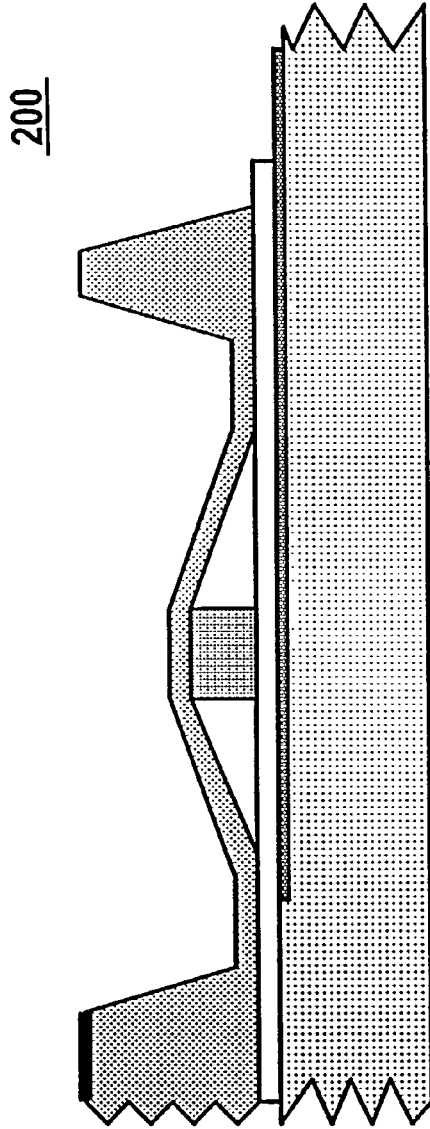

Fig. 10 B



200

Fig. 10C

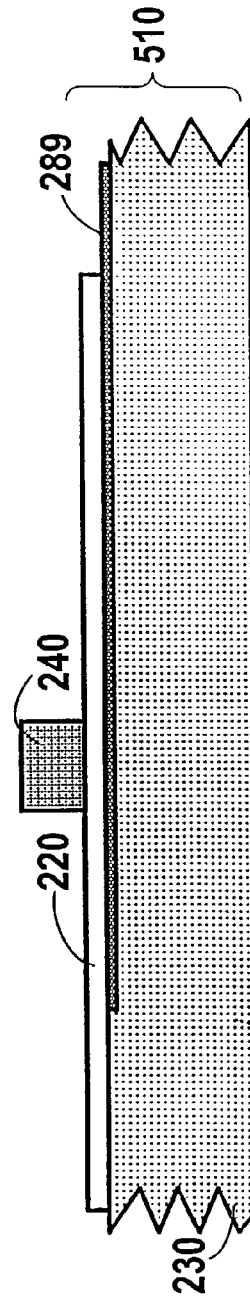

Fig. 10A

510

230

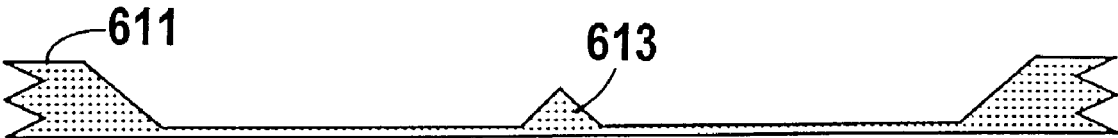

Fig. 11

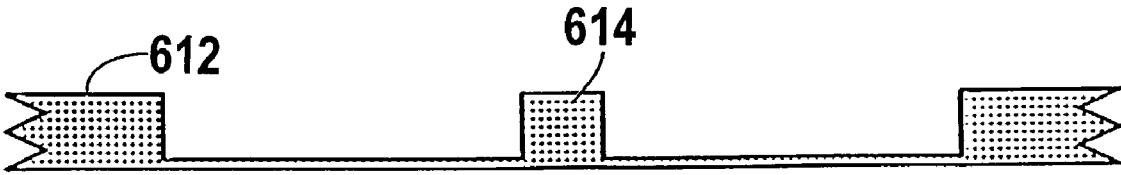
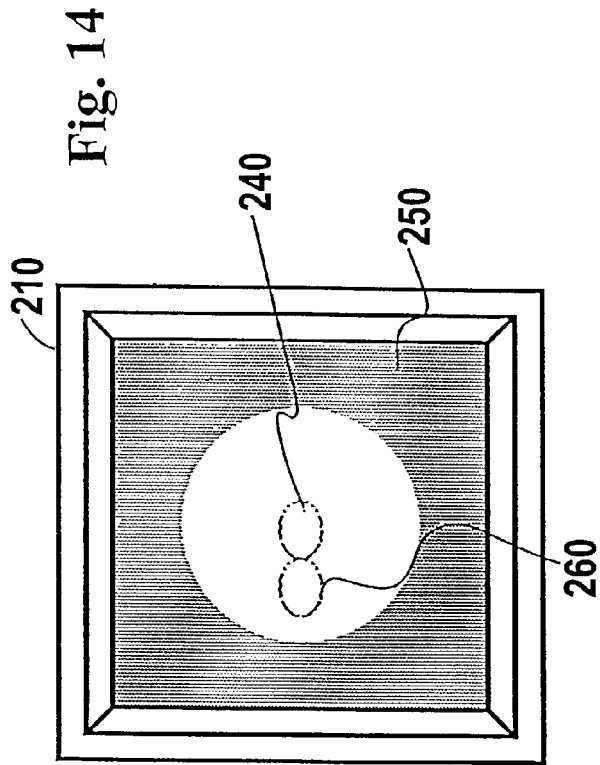
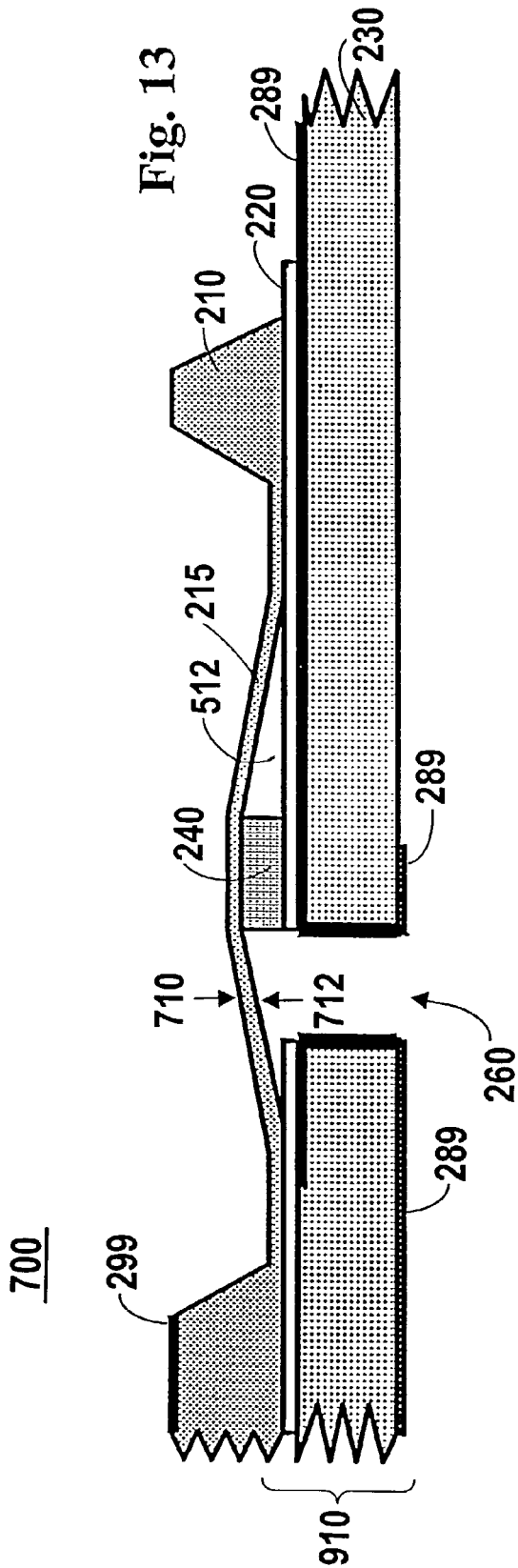

Fig. 12



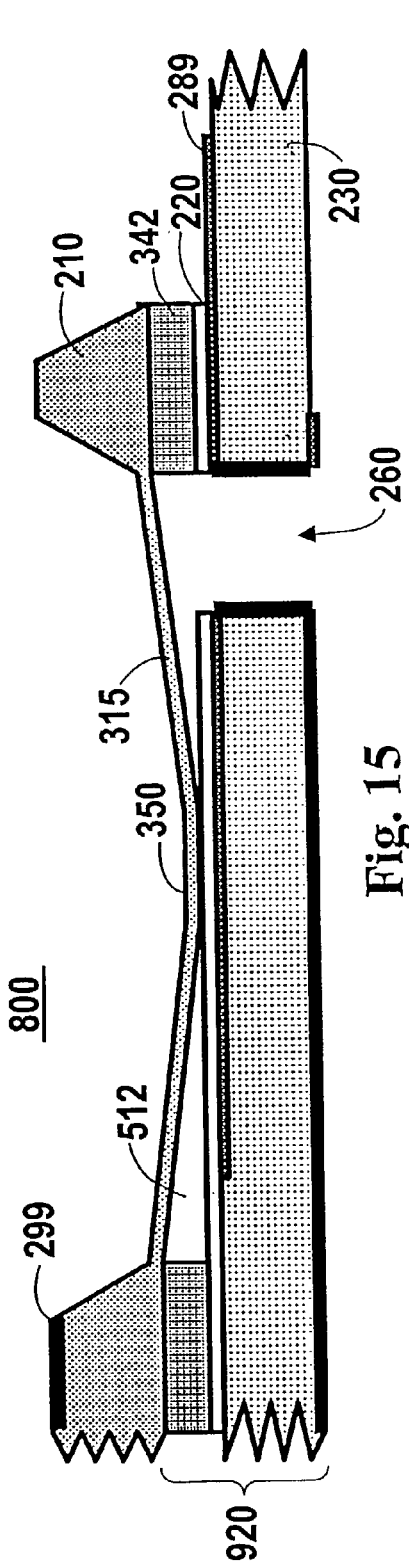

Fig. 15

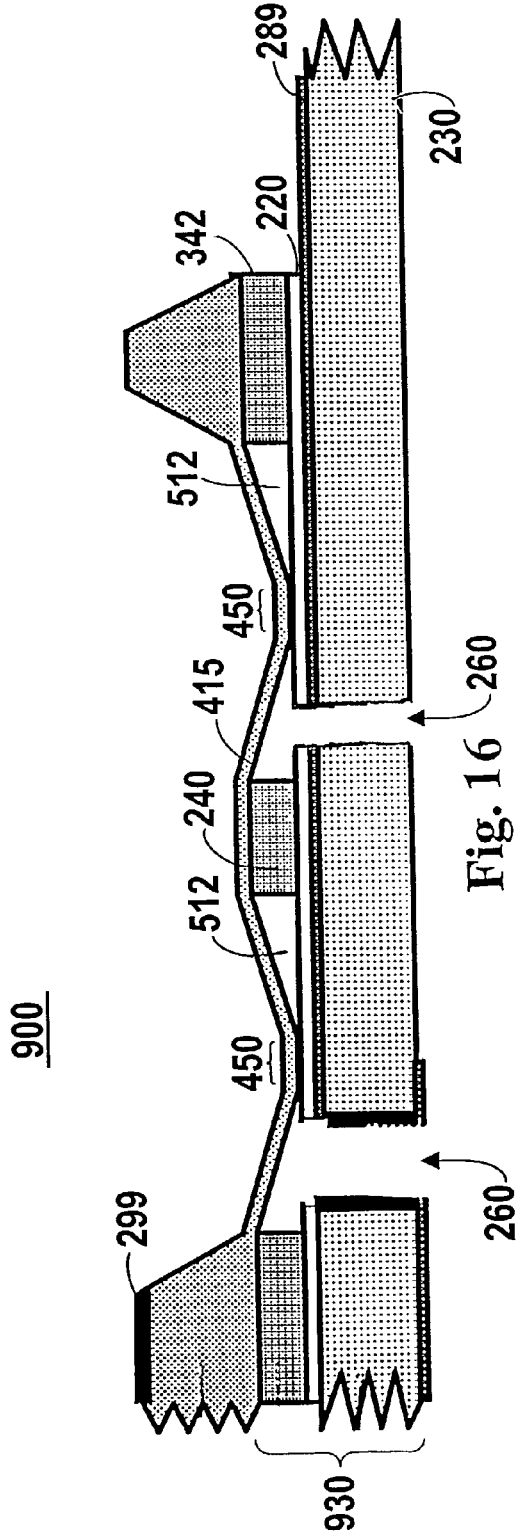

Fig. 16

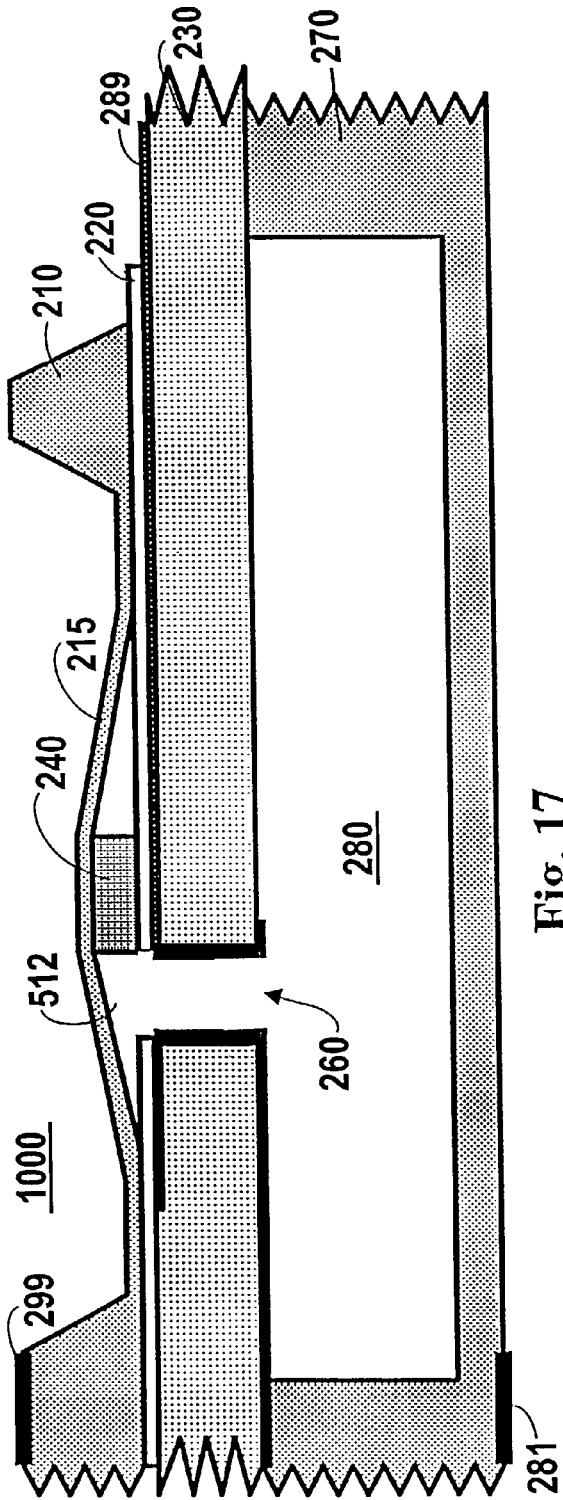

Fig. 17

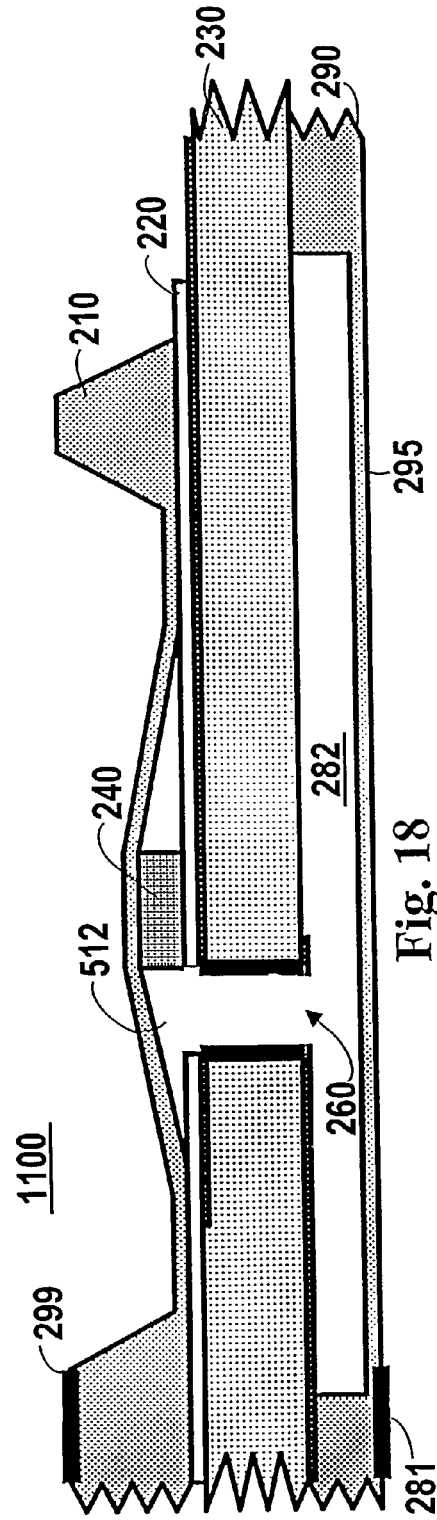

Fig. 18

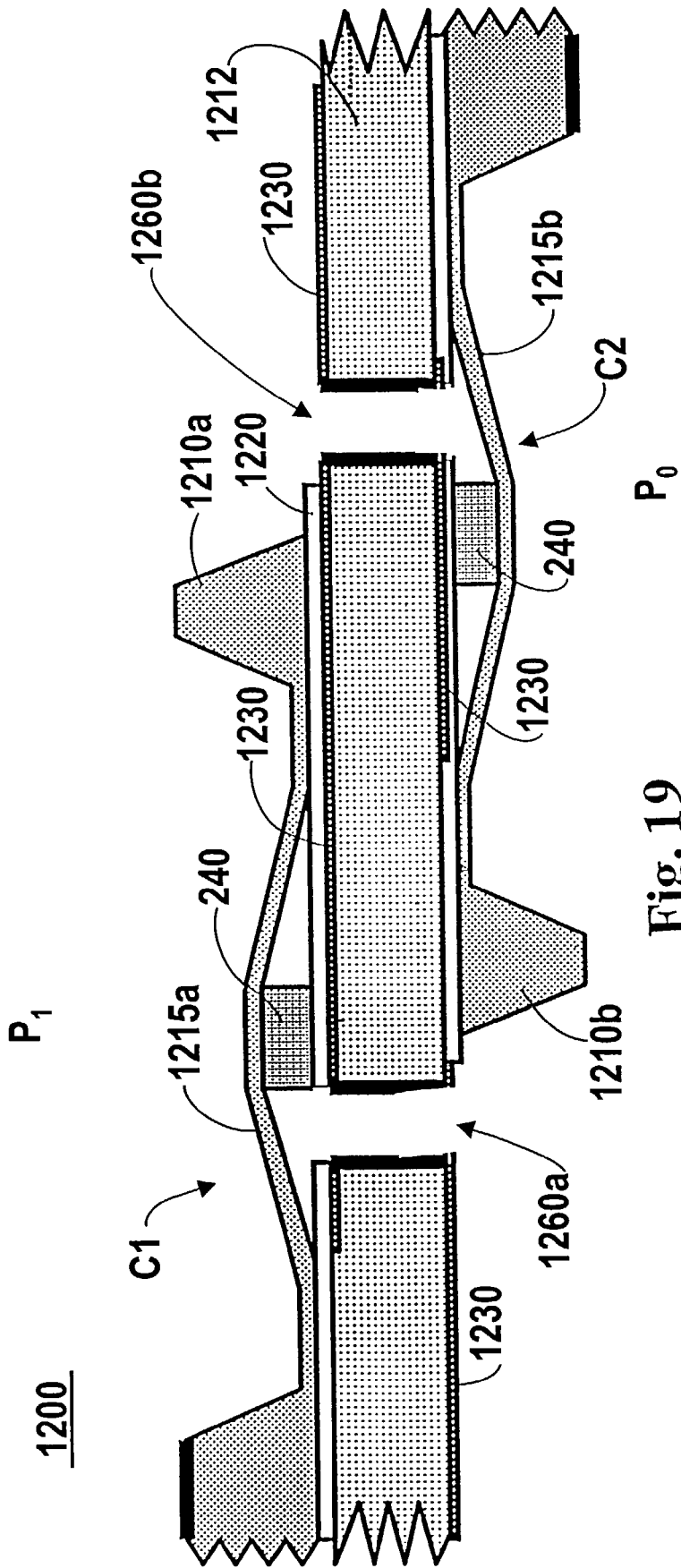

Fig. 19

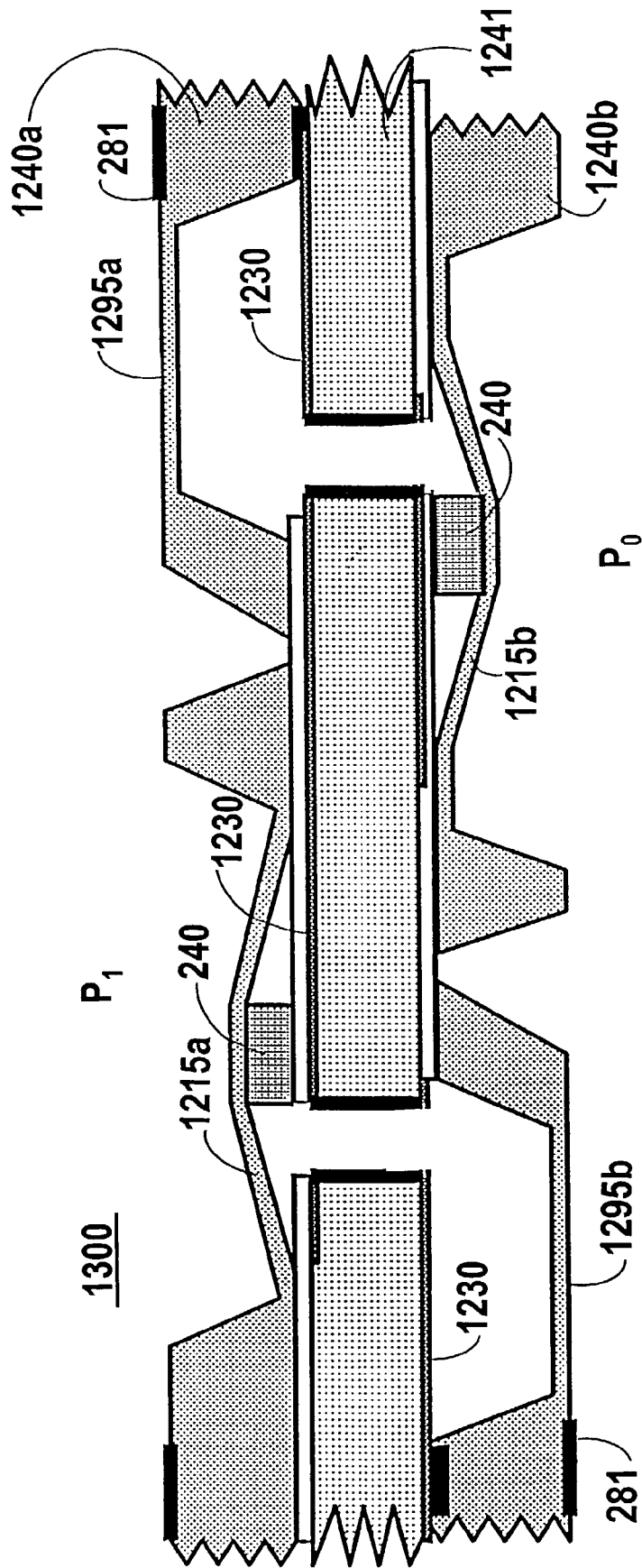

Fig. 20

3900

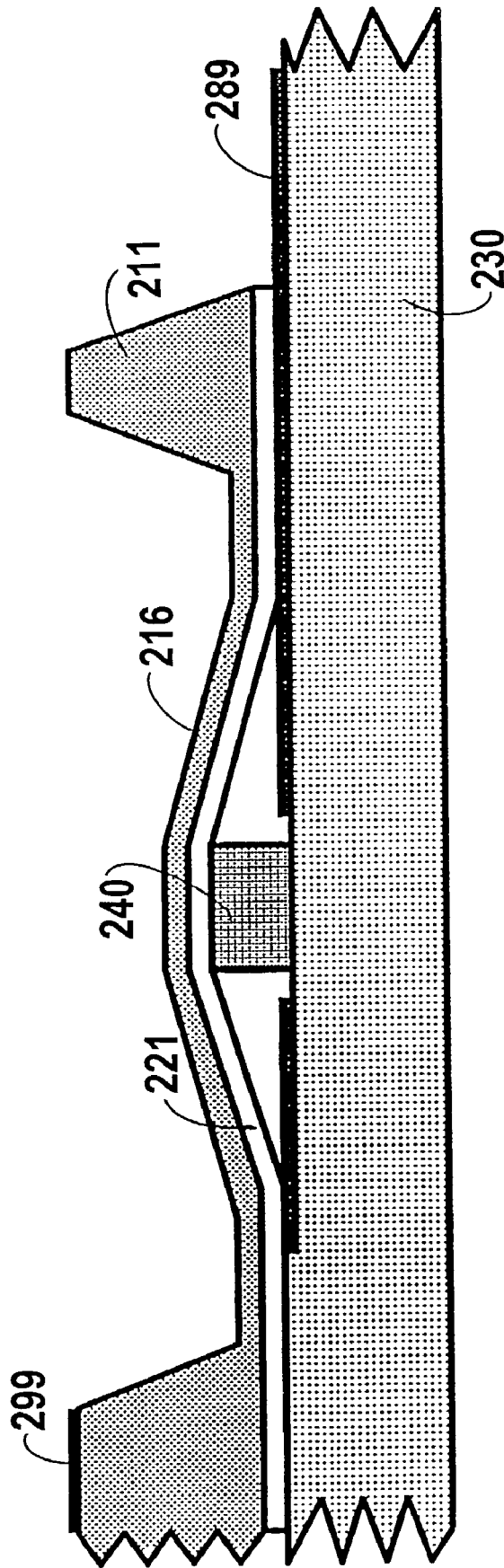

Fig. 21

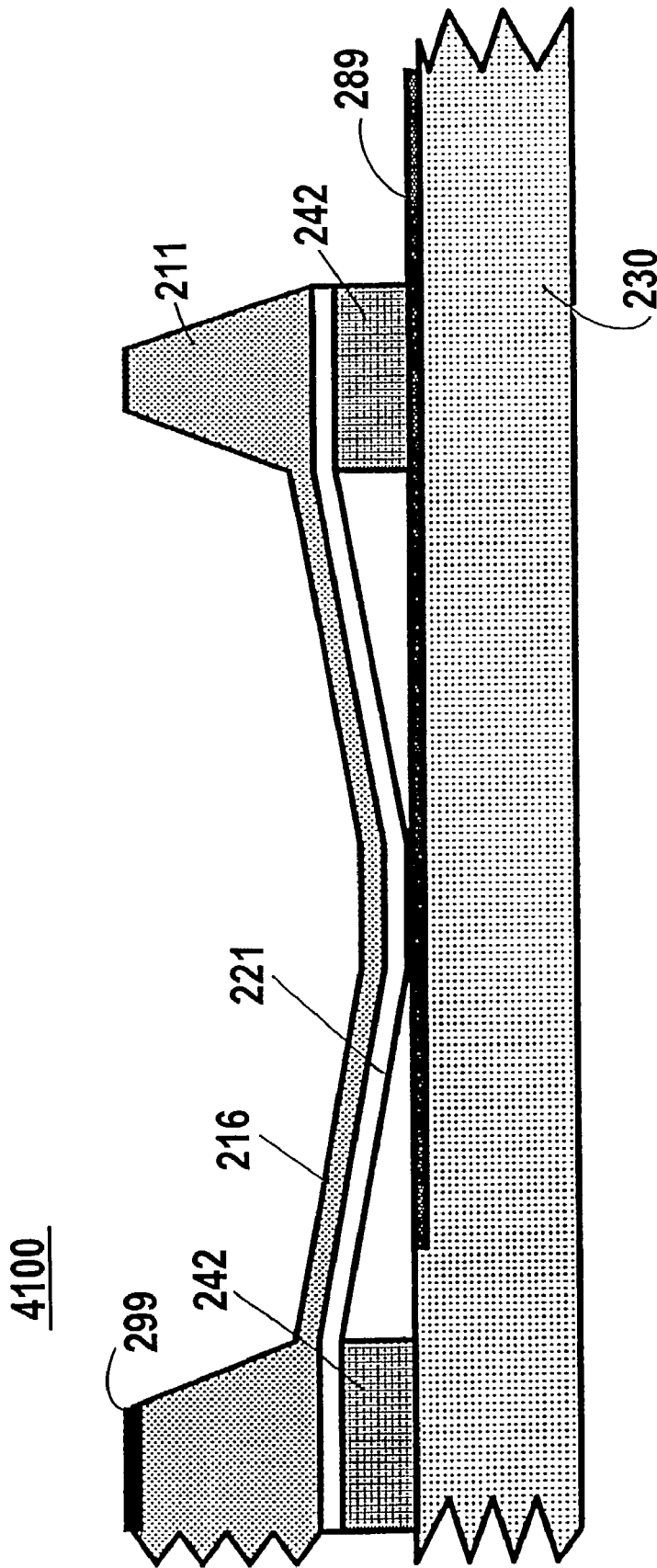

Fig. 22

MICRO-ELECTROMECHANICAL SENSOR

The present application claims priority under 35 U.S.C. §119 to U.S. provisional patent application bearing Ser. No. 60/306,175 filed Jul. 17, 2001.

FIELD OF THE INVENTION

The present invention relates generally to the field of micro-electromechanical systems (MEMS). More specifically, the present invention relates to micro-electromechanical variable capacitive sensors.

BACKGROUND OF THE INVENTION

Transducers are generally devices that convert an input of one form of energy into an output of another form of energy. Many types of transducers are available for converting light to electrical signals, mechanical energy to electrical signals, temperature to pressure, pressure to electrical signals, acceleration to electrical signals, electrical signals to motions, etc., and vice versa. Equipment or apparatus that operates between different types of energy generally requires one type of transducer or another. Based upon the application, transducers can range from inexpensive to very expensive, depending on the precision, accuracy, sensitivity, and reliability required.

A pressure transducer, in general, is a device that senses pressure and converts it to electrical energy. A type of conventional pressure transducer is a capacitive displacement transducer, an example of which is shown in FIGS. 1A and 1B. The conventional transducer has two glass strata 10 that sandwich a silicon stratum 12 metal electrodes 14 and 16 form the positive and negative capacitor plates, respectively. Silicon stratum 12 forms a thin diaphragm and similarly shallow gaps separate the diaphragm from the capacitor plates. The diaphragm deflects in response to the pressure difference between the two sides of the diaphragm. The deflection varies the separation between the diaphragm and the electrodes, diminishing one capacitance while increasing the other. The capacitances of the transducer, and thus the pressure associated with the capacitances, can be measured by using appropriate circuitry. A more detailed description of a capacitive displacement transducer device can be found in U.S. Pat. No. 4,996,627, entitled "High Sensitivity Miniature Pressure Transducer," which is hereby incorporated by reference.

One problem associated with such conventional transducer structures is thermal-mechanical mismatch between glass and silicon. Low pressure sensing requires a high aspect ratio diaphragm (e.g., high radius to thickness ratio) that acts as a tensile spring, the stiffness of which is mainly determined by its tension. Glass and silicon, however, do not have identical thermal expansion properties, and their differences can significantly affect the tension of the diaphragm. As a result, the accuracy of low pressure sensing transducers made with a glass-dominated structure varies, sometimes unpredictably, as a function of temperature. Tension in the diaphragm also varies from transducer to transducer, as it is difficult to precisely recreate the same tension in the diaphragms.

Also, most conventional transducers exhibit a constant sensitivity to the measured variable, e.g. pressure. Conventional pressure transducers, have output signals that generally increase linearly with applied pressure. The largest inaccuracy in conventional pressure transducers is composed of common-mode or absolute errors, the sources of

which are independent of pressure. This type of inaccuracy or error appears to be the same at every point in the measured range. Therefore, when expressed as a percent of reading, the error is smallest at the maximum pressure and highest at the minimum pressure. When the minimum pressure is zero, the error is then infinite. However, many applications require a transducer with great accuracy at the low end of the pressure range. Normal-mode inaccuracy appears as the same error percentage at every point in the measured range because the absolute error is reduced at the low pressure range. A transducer exhibiting only normal mode error is said to exhibit high "dynamic range". Given a maximum allowed percentage inaccuracy, dynamic range is expressed as the number of orders of magnitude of measured range for which a transducer measures within that accuracy. The resulting output signal characteristic is "log-linear" with respect to pressure. A highly sensitive pressure transducer that provides such a log-linear signal characteristic also exhibits maximum dynamic range. However, the art has failed to provide a micro-sensor that is relatively reproducible and cost effective to manufacture, while exhibiting the low range accuracy of relative error device.

SUMMARY OF THE INVENTION

An embodiment of the present invention is a variable capacitive micro-electromechanical transducer. In particular, a transducer according to the invention comprises a substrate that acts as an electrode of a capacitor, a dielectric material disposed on the substrate, a spacing member disposed on the dielectric material, and a resilient element disposed on the dielectric material as another electrode. A portion of the resilient element is separated from the dielectric material, while another portion of the resilient element is in contact with the dielectric material. In one embodiment, the contact area between the resilient element and the dielectric material, which approximately constitutes an effective electrode area for the capacitor, corresponds to a difference between the amount of an external force that is exerted on the resilient element and a component of the tension in the resilient element. The transducer capacitance can be readily measured, and the tension in the resilient element can be deduced from the transducer capacitance. Thus, the amount of external force that is exerted on the resilient element can be calculated from the transducer capacitance.

Unlike conventional capacitive displacement transducers, in which the tension of the resilient element is primarily determined by the dimensions of the resilient element, the tension of the resilient element of the present invention is secondarily determined by the dimensions of the resilient element and is primarily determined by the height of the spacing member. The dimensions of the resilient element and, to an even greater degree, the height of the spacing member can be finely controlled and reproduced using MEMS and other semi-conductor device fabrication processes and techniques. Therefore, the accuracy and precision of the pressure transducer of the present embodiment are dramatically improved over those of conventional pressure transducers.

Movement of the resilient element can be effected by many different means including changes in pressure, acceleration, etc. Thus, the transducers of the present invention can be configured as pressure transducers, accelerometers, densimeters, fluid flow meters, etc.

In one embodiment of the present invention, the spacing member may be positioned approximately at the center of

the resilient element. In this embodiment, the central portion of the resilient element is separated from the dielectric material by the spacing member, and a peripheral portion of the resilient element is in contact with the dielectric material. According to the present invention, a transducer having this configuration has a higher sensitivity to force changes at lower force ranges. In the present invention, the transducer configuration preferably exhibits a log-linear sensitivity to applied force, which can maximize dynamic range.

In another embodiment of the present invention, the spacing member may be positioned along a peripheral portion of the resilient element such that its peripheral portion is separated from the dielectric material. In this embodiment, the central portion of the resilient element is in contact with the dielectric material. According to the present invention, a transducer having this configuration has a higher sensitivity at higher force or pressure ranges.

In yet another embodiment of the invention, the spacing member may include two arts. One part is positioned approximately at the center of the resilient element, and another part is positioned along the peripheral region of the resilient element. In this embodiment, the contact area assumes an annular shape. The spacing member of such a transducer can be sized and positioned so that the transducer exhibits linear sensitivity to force or pressure.

In some embodiments, dielectric material may be disposed on the surface of the resilient element that faces the substrate. In these embodiments, the spacing member may be used to separate portions of the dielectric material and the resilient element from the substrate. The effective electrode area is approximately the contact area between the dielectric material and the substrate.

Another embodiment of the present invention is a pressure transducer for measuring differential pressure between two fluids. The pressure transducer of this embodiment includes a substrate that acts as a capacitor-electrode and resilient elements for bi-directional response disposed on opposite sides of the substrate. The resilient elements, which act as movable electrodes, and the substrate form two capacitors that share a common electrode. The transducer further includes openings through the substrate to allow the resilient elements to be exposed to both of the fluids. Differential pressure can be measured by measuring the capacitances of the two capacitors. In one preferred embodiment, the substrate is made of glass with a metallized layer, and the resilient elements are formed as diaphragms made of silicon. In this embodiment, the transducer can be constructed as an "all silicon structure" from silicon wafers. All silicon structures, which are composed of forms of silicon commonly found in MEMS and integrated circuits, would be less prone to the thermal-mechanical mismatch between glass and silicon.

In yet another embodiment of the present invention, a pressure transducer for measuring differential pressure includes a substrate, a resilient element disposed on one side of the substrate, and an isolator disposed on another side of the substrate. In a preferred embodiment, the isolator is formed as a membrane that prevents external fluids, which may alter the capacitance of the transducer or may chemically interact with the transducer, from being interposed between the resilient element and the substrate. A gauge fluid may be contained in the volume enclosed by the resilient element and the isolator to communicate pressure between the isolator and the resilient element. Once again, the resilient element may be formed as a diaphragm.

These and other embodiments of the present invention will be further described below.

BRIEF DESCRIPTION OF THE DRAWINGS

For a better understanding of the invention, reference should be made to the following detailed description taken in conjunction with the accompanying drawing(s), in which:

FIG. 1A is a cross sectional view of a prior art displacement capacitive pressure transducer;

FIG. 1B is schematic diagram illustrating a circuit equivalence of a prior art displacement capacitive pressure transducer;

FIG. 2 is a side cross-sectional view of a transducer configured to sense absolute pressure according to one embodiment of the present invention;

FIG. 3 is a top view of the transducer of FIG. 2 according to the present invention;

FIG. 4 is a side cross-sectional view of the transducer of FIG. 2 according to the present invention showing a greater applied force;

FIG. 5 is a top view of the transducer of FIG. 4 according to the present invention;

FIG. 6 is a side cross-sectional view of a transducer that is configured to sense absolute pressure according to another embodiment of the present invention with an applied force shown;

FIG. 7 is a side cross-sectional view of the transducer of FIG. 6 with a greater applied force;

FIG. 8 is a side cross-sectional view of a transducer with an applied force according to a further embodiment of the present invention;

FIG. 9 is a side cross-sectional view of the transducer of FIG. 8 with a greater applied force;

FIG. 10A is a side cross-sectional view of a processing step for fabricating a transducer, illustrating a base structure;

FIG. 10B is a side cross-sectional view of a processing step for fabricating a transducer, illustrating a diaphragm-stratum;

FIG. 10C is a side cross-sectional view of the completed process for fabricating a transducer, according to an embodiment of the present invention;

FIG. 11 is a side cross-sectional view of an alternative diaphragm-strata that may be used in an embodiment of the present invention;

FIGS. 12 is a side cross-sectional view of another alternative embodiment of diaphragm-strata that may be used in an embodiment of the present invention;

FIG. 13 is a side cross-sectional view of a transducer that is configured to sense differential pressure according to another embodiment of the present invention;

FIG. 14 is a top plan view of the transducer of FIG. 13;

FIG. 15 is a transducer that is configured to sense differential pressure according to another embodiment of the present invention;

FIG. 16 is a transducer that is configured to sense differential pressure according to yet another embodiment of the present invention;

FIG. 17 is a side cross-sectional view of a transducer that is configured to sense compressible fluid density according to a further embodiment of the present invention;

FIG. 18 is a side cross-sectional view of a transducer that is configured to sense differential pressure of hostile or sensitive fluids according to another embodiment of the present invention;

FIG. 19 is a side cross-sectional view of a pressure transducer that is configured to sense bi-directional differential pressure according to yet another embodiment of the present invention;

5

FIG. 20 is a side cross-sectional view of a differential pressure transducer that is configured to sense bi-directional differential pressure of hostile or sensitive fluids according to yet another embodiment of the present invention;

FIG. 21 is a side cross-sectional view of a transducer where the dielectric layer is disposed upon the resilient diaphragm according to yet another embodiment of the present invention; and

FIG. 22 is a side cross-sectional view of a transducer where the dielectric layer is also disposed upon the resilient diaphragm according to yet another embodiment of the present invention.

DESCRIPTION OF THE PREFERRED EMBODIMENTS

As shown in FIG. 2, transducer 200 according to an embodiment of the present invention comprises substrate 230, a dielectric 220 (which may be disposed on the substrate 230), spacing member 240, and resilient stratum 210 disposed over the dielectric 220. In the illustrated embodiment, substrate 230 includes an optional conductive layer 289 that acts as an electrode of the capacitor. The resilient stratum 210 includes a diaphragm portion 215 that is configured to act as another electrode of the capacitor. The diaphragm portion 215 is at least partially separated from the dielectric 220 by spacing member 240. As shown in FIG. 2, dielectric 220 comprises a layer of a dielectric material, which may be selected by a person skilled in the art from known dielectric materials. Alternatively, dielectric 220 may be configured as a vacuum layer. Void 222, which is created by spacing member 240 between diaphragm portion 215 and dielectric 220, may be evacuated or may contain a displaceable or compressible non-conductive fluid (e.g., air), preferably at an initial predetermined pressure. Capacitance measuring circuitry may be coupled to the transducer 200 via electrical contact 299 and conductive layer 289 as will be appreciated by those of ordinary skill in the art.

According to the present embodiment, tension causes diaphragm portion 215 to act as a spring or resilient element that resiliently deforms in response to external forces (e.g., pressure). Tension also assists the diaphragm portion 215 to "spring back" to its original shape when the external forces are removed. In other words, this tension affects how much the diaphragm portion 215 will bend and come into contact with the layer of dielectric material in response to an external force. In the present embodiment, the tension in the diaphragm portion 215 is determined primarily by the height of the spacing member 240 and also by the dimensions (e.g., radius and thickness) of the diaphragm portion 215. The height of the spacing member 240 and the dimensions of diaphragm portion 215 can be finely controlled and reproduced using known MEMS fabrication processes and semiconductor device fabrication processes. Therefore, the accuracy and precision of a transducer of the present embodiment are dramatically improved over those of conventional transducers.

In general, for MEMS applications the diameter of the diaphragm portion will be not greater than about 5 mm, typically between about 50 microns to 5 mm, perhaps lower for nano-applications (e.g., 5 microns). Typical heights and diameters for the spacing member may be about 1–5 microns and 30–70 microns, respectively. Strain, an indicator of tension in the diaphragm portion, is preferably in the range of about 0.001%–0.1%. In one preferred embodiment, configured for low pressure sensing (e.g., full scale pressure in the range of about one inch of water column or less,

6

approximately 0.035 psi), the thickness of diaphragm portion 215 may range from less than a micron (e.g., 0.1 micron) to more than ten microns, and the area of the diaphragm portion may be more than one square millimeter (1 mm²). More specifically, the diameter is about 1 mm. The height and diameter of spacing member 240 is about 3 microns and 50 microns, respectively. At these dimensions, the strain in the diaphragm portion is about 0.01%.

FIG. 3 depicts a top view of the diaphragm portion 215 and illustrates contact area 250 (shaded gray) between the diaphragm portion 215 and the dielectric 220. The white circular area thus represents void 222. Although spacing member 240 is shown in hidden lines to be cylindrical in shape, located beneath approximately the center of diaphragm portion 215, it should be understood that in alternative embodiments, spacing member 240 may be located at any position under diaphragm portion 215, and may be configured in other than cylindrical shape. For example, multiple spacing members may be located between diaphragm portion 215 the substrate 230 to define contact area 250.

The size of contact area 250 varies in response to the amount of force exerted on the diaphragm portion 215. As the amount of force exerted increases, a larger part of the diaphragm portion 215 presses against the dielectric material 220, increasing the size of the contact area 250. The capacitance of the device is determined by the amount of the diaphragm portion in contact with the dielectric material. Thus, force exerted to increase contact area 250 increases the effective electrode area and capacitance of the transducer 200 correspondingly. FIGS. 4–5 thus illustrate transducer 200 with larger external force exerted on diaphragm portion 215. As will be appreciated, decreasing the force on diaphragm portion 215 decreases the contact area 250 resulting in a corresponding decrease in the effective electrode area and capacitance of transducer 200. Therefore, the amount of force exerted on the diaphragm 215 can be determined by measuring the capacitance of the transducer 200.

Capacitance of transducer 200 may be measured by coupling the diaphragm portion and substrate to a capacitance measuring circuit, which is well known in the art. In some embodiments, the transducer 200 may be calibrated by measuring its capacitance while applying known amounts of force on the transducer and determining a correlation function between the measured capacitances and the amounts of force applied. In other embodiments the capacitance may be held at a predetermined constant value by applying a voltage to the capacitor so that the attendant electrostatic force causes the capacitance to increase and approach the predetermined constant value. The voltage required to reach the predetermined capacitance may also be calibrated to represent the force or pressure applied to the transducer.

In the embodiment illustrated in FIGS. 2–5, as discussed above, contact area 250 increases with increasing applied force as the contact radius decreases. Diaphragm portion 215 becomes stiffer as contact area 250 increases and the area in contact increases at a decreasing rate with incremental contact radius decrease. Diaphragm portion 215 deflects until the sensed force is balanced by the net, normal component of the tension in diaphragm portion 215.

In this preferred embodiment the increase in tension, as diaphragm portion 215 deflects, gives rise to non-linear characteristics of the transducer. Thus, the first increment of contact area change is the largest, and capacitance increases at a decreasing rate with increasing force. Taking advantage of these unique properties, sensors made according to the present invention may be used to accurately sense very small

forces and force changes because the sensor response results in a relative or normal-mode error condition. For example, when the actuating force to be sensed is pressure, the present embodiment provides the greatest differential capacitance to pressure ration (dC/dP) at the low pressure range, resulting in a substantially uniform relative error function across the entire pressure range. Depending on selection of parameters such as spacing member height and diaphragm dimensions and materials, the resulting change of output capacitance may be controlled as approximately proportional to the logarithm of the sensed force. This configuration is particularly useful to applications where a high dynamic range (i.e., high measurement resolution over several orders of magnitude) is desired. A high dynamic range signal configuration may be best for applications where the sensed variable varies by an exponential that is less than unity with the measured variable. For example, transducer **200** is suitable for measuring fluid flow rate, which is proportional to the square-root of the sensed fluid pressure ($P^{1/2}$). Thus, transducer **200** may be incorporated into fluid flow meters and fluid flow controllers.

FIGS. **6** and **7** illustrate a transducer **300** according to another embodiment of the present invention. In general, transducer **300** is constructed in similar fashion to transducer **200**, but with the variations discussed below. In transducer **300**, the peripheral part of a diaphragm portion **315** is separated from the dielectric material **220** by a peripheral spacing member **342** that is positioned around the perimeter of diaphragm portion **315**. The central part of diaphragm portion **315** is in contact with the dielectric material **220** to form contact area **350**. In one embodiment, a small central part of diaphragm portion **315** may be fixedly bonded to the dielectric material **220** to define a minimum contact area **350** and thus ensure a minimum capacitance. Once again, the size of the contact area **350** varies with the amount of force exerted on the diaphragm portion **315**, and the size of the contact area **350** determines the capacitance of the transducer **300**.

In an embodiment such as transducer **300**, contact area **350** increases as the contact radius increases and diaphragm portion **315** becomes stiffer with increasing applied force. The dominant signal-shaping phenomenon results from the contact area increasing at an increasing rate with incremental contact radius increase. Therefore, capacitance increases at an increasing rate with increasing force. This configuration may be most suitable for applications where the sensed variable varies by an exponential that is greater than unity with the measured variable. For example, transducer **300** is suitable for measuring fluid quantity in tanks that are larger at the bottom than at the top and/or measuring fluid quantity in tanks having a constant volume to depth ratio wherein the fluid contained has a density proportional to its depth.

According to the embodiment of FIGS. **6** and **7**, peripheral spacing member **342** may be made of the same material as spacing member **240**. That is, the peripheral spacing member **342** may be a separate structure or a metal or oxide deposited on substrate **230** or dielectric layer **220** in a precise and controlled fashion.

FIGS. **8** and **9** illustrate transducer **400** according to yet another embodiment of the present invention. In this embodiment, diaphragm portion **415** is elevated both at a central point and around a peripheral part by central spacing member **240** and peripheral spacing member **342**, respectively, to define contact area **450** with an annular shape. Diaphragm portion **415** may be bonded to dielectric layer **220** over a predetermined area to ensure a minimum contact area and capacitance. As depicted in FIGS. **8** and **9**, the size

of contact area **450** varies with the amount of force exerted on diaphragm portion **415**. This configuration may be most suitable for applications requiring a linear response to applied force. The contact radius without applied force can be chosen so that signal-shape is linear with applied force.

It will be appreciated that the movement of the diaphragm portion of the embodiments described herein can be effected by many different means including changes in fluid pressure, acceleration, etc. Thus, the embodiments of the present invention can be configured as absolute pressure sensors, differential pressure sensors, accelerometers, densimeters, thermometers, flow controllers, etc.

Transducers according to the present invention can be fabricated using known MEMS manufacturing processes and/or other known semiconductor device fabrication processes. Processes for fabricating the transducers according to the present invention may differ depending on the applications and utilities of the transducers that the process is designed to make. For example, a flow controller incorporating embodiment(s) of the present invention may preferably be fabricated using an alloy bonding process, whereas a densimeter incorporating embodiment(s) of the present invention may preferably be fabricated using an anodic bonding process. The materials used for making the transducers of the present invention may also differ depending on the intended applications and utilities.

FIGS. **10A–C** depict an exemplary series of process steps for fabricating a transducer according to the invention, such as transducer **200** of FIGS. **2–5**. Substrate **230** is first provided. As may be determined by a person of ordinary skill, substrate **230** may include a non-conducting substrate (e.g., glass substrate) having a conductive layer (e.g., a metallized layer). Metallized glass wafer, single crystal silicon wafer and/or other suitable materials may be used as the substrate **230**. In one embodiment, the substrate **230** is made with a glass material with a thermal-expansion coefficient that closely matches that of silicon.

As shown in FIG. **10A**, a base structure **510** may be fabricated by first forming or depositing dielectric material **220** on substrate **230**, and then forming the spacing member **240** thereon. Such a process is particularly useful where substrate **230** is a metallized glass substrate. The layer of dielectric material **220** may be a layer of silicon dioxide or a layer of silicon nitride. Other insulators with high dielectric constant can also be used.

Resilient-stratum **210**, shown in FIG. **10B**, may be fabricated by etching a silicon-on-insulator (SOI) wafer, a single crystal silicon wafer, or polysilicon wafer. A dry gaseous isotropic deep etching process may be used. A portion of the resilient-stratum **210** may be metallized to form an electrical contact **299**. In an alternative embodiment, spacing member may be formed on or as part of resilient-stratum **210**.

The resilient-stratum **210** and the base structure **510** are then bonded together as shown in FIG. **10C**. Anodic bonding and/or alloy bonding processes may be used to bond the resilient-stratum **210** and the base structure **510** together.

As mentioned, the tension in diaphragm portion **215** is primarily determined by the height of spacing member **240** and also by the dimensions of the diaphragm portion. The height and dimensions can be accurately controlled and reproduced in many devices using known MEMS fabrication and/or semiconductor device fabrication processes and techniques. Because the height of spacing member **240** and the dimensions of the diaphragm portion **215** are accurately reproducible, transducers of the present invention with almost identical diaphragm tension can be mass produced.

FIGS. 11 and 12 depict two alternative resilient strata 611 and 612 that may be used in embodiments of the present invention as alternatives to resilient strata 210 discussed above. For example, given their shapes, strata 210 and 612 are suitable for forming by dry etching. Stratum 611 is alternatively suitable for forming by wet-etching. Different patterns may be formed on the stratum and various materials (e.g., metals, metal oxides, etc.) can be deposited or grown thereon, such as protrusions 613 and 614, to vary the mechanical and/or electrical properties. Although the resilient strata have been discussed herein principally in terms of diaphragm-like configurations suitable for sensing pressure according to preferred embodiments of the invention, other shapes or structures may be suitable for sensing other types of forces. For example, in accelerometer applications, a bar or strip member may be employed. Also, to increase sensitivity in selected ranges, the mass may be altered, either uniformly or by adding mass concentrations. As an example, stratum 612 may be formed as a strip with protrusion 614 forming a mass concentration. When formed as a strip, stratum 612 may be secured to the substrate only at opposite ends, however when formed as a diaphragm the stratum is secured around its periphery.

In another alternative embodiment shown in FIGS. 13 and 14, transducer 700 also includes substrate 230, dielectric material 220 disposed on substrate 230 and spacing member 240 which comprise base structure 910. Resilient-stratum 210 is disposed on dielectric material 220 of the base structure. The resilient-stratum 210 forms diaphragm portion 215 stretched across spacing member 240 as previously discussed. In this embodiment, opening 260 is provided through substrate 230, communicating with void 512. (Spacing member 240 and opening 260 are illustrated by hidden lines in FIG. 19). With this arrangement, transducer 700 can be used to measure the differential pressure between two fluids on opposite sides of the device. When one surface 710 of diaphragm portion 215 is exposed to a first fluid, and when the opposite surface 712 is exposed to a second fluid that enters void 512 through opening 260, the differential pressure between the two fluids may be determined by measuring the capacitance of transducer 700.

FIGS. 15 and 16 depict transducers 800 and 900 according to further alternative embodiments of the present invention. Transducer 800 includes base structure 920 with peripheral spacing member 342 and opening 260 for providing access to void 512. Transducer 900 includes base structure 930, with central spacing member 240, peripheral spacing member 342 and plural openings 260 communicating with the plural voids 512 formed by the annular shape of contact area 450. Both transducers 800 and 900 can be used for measuring the differential pressure between two fluids as discussed above with respect to transducer 700.

Transducers 700, 800 and 900 may be fabricated in a series of steps similar to those illustrated in FIG. 14. As mentioned, embodiments of the present invention can be made using different processes, and the processes used may differ depending on the applications for which transducers are designed. For example, either of resilient strata 611 or 612 may be bonded with any of base structures 910, 920 or 930. Fabricating techniques described above in conjunction with FIG. 14 may also be used to make transducers 700, 800 and 900. Other MEMS fabrication and semiconductor device fabrication processes and techniques may also be used.

In yet another embodiment of the present invention shown in FIG. 17, transducer 1000 includes silicon substrate 270 bonded to substrate 230 to define fixed-boundary chamber

280. A metal or metallized contact 281 may be provided on substrate 270 to allow coupling to an associated capacitance measuring circuit. When the substrates are assembled, chamber 280 may be initially filled with gaseous fluid, pressurized at a level slightly lower than a lowest external pressure to be sensed. Alternatively, chamber 280 may contain a vacuum. Chamber 280 is in communication with void 512 through opening 260. In this embodiment, diaphragm portion 215 deflects with little impedance until the differential pressure across the diaphragm 215 is balanced by the net, normal component of its tension, which opposes the differential pressure.

Preferably, the fluid in chamber 280 is identical to the fluid interfacing the outer surface of diaphragm portion 215. Also, diaphragm portion 215 is preferably sufficiently compliant so as to behave as a tonometric membrane, e.g. the skin of a perfect balloon. Such a tonometer supports neither a pressure gradient nor a temperature gradient across its thickness and therefore, the fluid density on both surfaces of the diaphragm portion must be the same. The larger the volume of gas in the chamber, the more the diaphragm portion must deflect to accommodate a change in density of the outer fluid. The larger the diaphragm portion deflection, the larger the change in capacitance. In this way, the transducer 1000 acts as a capacitive densimeter whose sensitivity is proportional to the volume of the fixed-boundary chamber 280.

A device such as transducer 1000 may be applied as the density correction component for flow measurement and control of a compressible fluid. Another component for flow sensing may be a differential pressure sensor configured like transducer 700 of FIG. 13. Monolithic sensors for sensing fluid flow may contain components configured in a manner similar to transducer 700 and to transducer 1000 so as to provide the function P/n , where P denotes differential pressure and n denotes the density of the fluid to be measured.

In another alternative embodiment shown in FIG. 18, transducer 1100 is also configured for measuring differential pressure between two fluids. This embodiment also includes substrate 230 that is configured to act as an electrode and diaphragm portion 215 that is configured to act as another electrode. However, a further substrate 290 is provided with an isolator diaphragm 295 to thus define variable-boundary chamber 282. Isolator diaphragm 295 may be fabricated as part of substrate 290, which is bonded to substrate 230. In one alternative, isolator diaphragm 295 is more compliant than diaphragm portion 215. A non-conducting gauge fluid is preferably contained in the void between diaphragm portion 215 and the isolator diaphragm 295. A person of ordinary skill in the art may select an appropriate material and process for fabricating diaphragm 295 based on its compatibility with the fluids to be isolated.

With reference still to FIG. 18, it will be noted that one surface of diaphragm portion 215 is exposed to a first fluid of interest. Thus, pressure of that fluid is directly communicated to the transducer. On the opposite side, one surface of isolator diaphragm 295 is exposed to a second fluid of interest, and the pressure of the second fluid of interest is communicated to the transducer via diaphragm portion 215 through isolator diaphragm 295 and the gauge fluid. Thus, this embodiment is particularly useful when the second fluid of interest may affect the dielectric constant of the dielectric medium between diaphragm portion 215 and the substrate 230 or otherwise be incompatible with the transducer layers.

Embodiments described above may be used as uni-directional sensors for sensing "positive" pressure. Generally, pressure is a scalar variable that acts equally in all directions.

11

Increasing or decreasing pressure in one location relative to another may be referred to as the direction of pressure. Typically, if the fluid pressure to be sensed is increasing relative to a reference pressure, the sensed pressure is said to be becoming more positive. In embodiments described above, in a null condition at which diaphragm tension is produced solely by the spacing member (and gravity depending on the application), the capacitance of the transducers changes predictably in response to positive pressure changes.

To more accurately sense bi-directional differential pressure changes, transducer **1200** according to a further alternative embodiment of the present invention is shown in FIG. **19**. Transducer **1200** includes a tri-strata structure with two silicon resilient strata **1210a** and **1210b** and glass stratum **1212** therebetween. The glass stratum **1212**, each surface of which preferably includes a layer of conductive material **1230** (e.g., metal), is configured to act as an electrode. Silicon strata **1210a** and **1210b** include diaphragm portions **1215a–1215b** that are configured to act as movable electrodes in the same manner as discussed above. Diaphragm portion **1215a** of silicon resilient stratum **1210a** forms a first capacitor **C1** with the conductive material **1230**, and diaphragm portion **1215b** of silicon resilient stratum **1210b** forms a second capacitor **C2** with the conductive material **1230**. A thin layer of dielectric material **1220** may be disposed on the conductive material **1230** such that the diaphragms **1215a–1215b** will not be in direct contact with the electrode **1230**. Openings **1260a–1260b** through the glass stratum **1212** may be optionally provided such that diaphragm portions **1215a–1215b** are exposed at their interiors to the fluids of interest.

Transducer **1200** uses first diaphragm portion **1215a** to sense pressure if P_1 is larger than or equal to P_0 . This is because the effective electrode area, as well as the capacitance of **C1** reaches a minimum point when the pressure difference ($P_1 - P_0$) is zero and any further decrease is minimal as the pressure difference ($P_1 - P_0$) becomes increasingly negative. When the pressure difference ($P_1 - P_0$) is negative, transducer **1200** uses second diaphragm portion **1215b** to sense the negative pressure because the effective electrode area, as well as the capacitance of **C2** does not increase unless the pressure difference ($P1 - P0$) is negative, and because the capacitance of **C2** increases as the difference ($P1 - P0$) becomes increasingly negative. As long as the pressure difference ($P1 - P0$) is positive, the capacitance of **C2** remains approximately constant. In an analogous manner, as long as the pressure difference ($P1 - P0$) is negative, the capacitance of **C1** remains approximately constant. Thus, changes in the pressure difference ($P1 - P0$) are approximately proportional to changes in the capacitance of **C1** or **C2**, depending on whether ($P1 - P0$) is positive or negative.

FIG. **20** depicts a differential pressure transducer **1300** in accordance with yet another embodiment of the present invention. In this embodiment, the transducer **1300** has two silicon resilient strata **1240a** and **1240b** disposed on opposite sides of glass stratum **1241**. Transducer **1300** has two isolator diaphragms **1295a–1295b** configured to prevent the inner surfaces of diaphragm portions **1215a–1215b** from being directly exposed to the fluids to be measured. In this embodiment, a gauge fluid is contained in the void between diaphragm portions **1215a–1215b** and the isolator diaphragms **1295a–1295b**. As described above, the transducer **1300** uses diaphragm **1215a** to sense pressure when the

12

pressure difference ($P1 - P0$) is positive, and uses diaphragm **1215b** to sense pressure when the pressure difference ($P1 - P0$) is negative.

In the embodiments illustrated, for example, in FIGS. **19–20**, silicon-glass-silicon strata are used. However, it should be appreciated that other materials may be used as alternatives. Persons of ordinary skill in the art will be able to select appropriate materials combinations for particular applications based on the teaching of the present invention.

Some embodiments of the present invention described above include a substrate that has a thin layer of dielectric material. Thus, in those embodiments, a spacing member separates the resilient element (e.g., a diaphragm) from the dielectric material. It should be noted that, in other embodiments, the layer of dielectric material may be deposited on the diaphragm or on both the diaphragm and the substrate. Transducer **3900** according to such an embodiment is illustrated in FIG. **21**. Transducer **3900** includes substrate **230** that acts as an electrode of a capacitor with spacing member **240** disposed on (or formed as part of) the substrate. Resilient stratum **211** is disposed over substrate **230** and spacing member **240**. Resilient-stratum **211** has a layer of dielectric material **221** attached thereto and a diaphragm portion **216** that acts as another electrode of the capacitor. Diaphragm portion **216** and the layer of dielectric material **221** are at least partially separated from substrate **230** by spacing member **240**. The operation principles of the transducer **3900** are similar to those of other embodiments of the present invention described above.

Transducer **3900** can be fabricated using known MEMS manufacturing processes, preferably micromachining or other MEMS process known to those of ordinary skill in the art, and/or semiconductor device fabrication processes and/or combinations thereof. For example, substrate **230**, which may be part of a metallized glass wafer, may be first provided. Spacing member **240** is then deposited on substrate **230**, either as a separate structure or as an integrally created part with the substrate. Spacing member **240** may itself be metallic. Substrate **230** may be made with a glass material having a thermal-expansion coefficient that closely matches that of silicon. Alternatively, substrate **230** may be made with silicon to circumvent the thermal-expansion mismatch problem. Metal contact **289** may be deposited or bonded on the substrate either before or after spacing member **240** is added, depending on the technique employed to provide the spacing member.

Resilient-stratum **211** may be separately formed by etching a substrate, which is preferably part of a silicon-on-insulator (SOI) wafer. In one embodiment, a dry gaseous isotropic deep etching process is preferably used. The layer of dielectric material **221** may be formed on the surface of diaphragm portion **216** using known semiconductor device fabrication processes. In one embodiment, dielectric material **221** may be silicon nitride or silicon dioxide. Metal contact **299** is added at an appropriate processing step. The combined resilient-stratum **211** and dielectric material **221**, and the base structure of substrate **230** and spacing member **240** may be bonded together to form the transducer **3900**, preferably using anodic or alloy bonding.

Transducer **4100** according to another embodiment of the present invention is shown in FIG. **22**. Transducer **4100** is similar to transducer **3900** except that transducer **4100** has a peripheral spacing member **242** as previously described. Other spacer configurations are also possible. Transducer **4100** may be fabricated using processes similar to those described above.

13

The foregoing description, for purposes of explanation, uses specific nomenclature to provide a thorough understanding of the invention. However, it will be apparent to one skilled in the art that the specific details are not required in order to practice the invention. Thus, the foregoing descriptions of specific embodiments of the present invention are presented for purposes of illustration and description. They are not intended to be exhaustive or to limit the invention to the precise forms disclosed. For instance, although some embodiments described and illustrated pertain to fluid pressure sensors, it should be understood that principles of the present invention may be applied to other areas such as accelerometers, air speed measuring devices, etc. Also, the fact that examples are given with respect to MEMS scale devices does not limit the scope or applicability of the invention. The principles and teachings of the present invention may be usefully applied on any scale. Many modifications and variations are possible in view of the above teachings.

What is claimed is:

1. A device, comprising:

a substrate configured to act as a first electrode of a capacitor;

a resilient element, configured to act as a second electrode of the capacitor, at least a first portion of which is secured at a position spaced from the substrate by a predetermined gap;

a layer of dielectric material disposed between the substrate and the resilient element, said layer having a thickness corresponding to said predetermined gap; and

a spacing member configured to separate a second portion of the resilient element from the substrate by a distance greater than said predetermined gap to define an effective electrode area of the capacitor corresponding to an area wherein the substrate and resilient element are separated by said predetermined gap, the effective electrode area changing in response to movement of the resilient element relative to the substrate and resulting in a change in capacitance of the capacitor.

2. The device of claim 1, wherein said spacing member is configured and dimensioned to provide a predetermined tension in said resilient element.

3. The device of claim 1 or claim 2, wherein said layer of dielectric material is disposed on the substrate and said spacing member separates said second portion of said resilient element from said dielectric material.

4. The device of claim 3, wherein said spacing member is configured to separate a central portion of the resilient element from the layer of dielectric material such that a peripheral portion of the resilient element is in contact with the layer of dielectric material.

5. The device of claim 3, wherein said spacing member is configured to separate a peripheral portion of the resilient element from the layer of dielectric material such that a central portion of the resilient element is in contact with the layer of dielectric material.

6. The device of claim 3, wherein said spacing member comprises:

a first portion configured to separate a central portion of the resilient element from the layer of dielectric material; and

a second portion configured to separate a peripheral portion of the resilient element from the layer of dielectric material such that an intermediate portion of the resilient element is in contact with the layer of dielectric material.

14

7. The device of claim 3, wherein a first surface of the resilient member is configured to be exposed to a first fluid, and wherein said device further comprises an opening defined by the substrate so as to expose a second surface of the resilient member to a second fluid.

8. The device of claim 7, further comprising a fixed boundary chamber disposed on the substrate opposite the resilient member for containing the second fluid.

9. The device of claim 7, further comprising a variable boundary chamber disposed on the substrate opposite tile resilient member for containing said second fluid.

10. The device of claim 1 or claim 2, wherein a layer of dielectric material is disposed on a surface of the resilient element facing the substrate.

11. The device of claim 10, wherein said spacing member is configured to separate a central portion of the layer of dielectric material from the substrate such that a peripheral portion of the layer of dielectric material is in contact with the substrate.

12. The device of claim 10, wherein said spacing member is configured to separate a peripheral portion of the layer of dielectric material from the substrate such that a central portion of the layer of dielectric material is in contact with the substrate.

13. The device of claim 10, wherein said spacing member comprises:

a first portion configured to separate a central portion of the layer of dielectric material from the substrate; and

a second portion configured to separate a peripheral portion of the layer of dielectric material from the substrate such that an intermediate portion of the layer of dielectric material is in contact with the substrate.

14. The device of claim 7, wherein said first fluid has a first pressure, and said second fluid has a second pressure, whereby the contact area between said resilient element and said substrate changes as a function of the difference between said first and second pressures.

15. A device, comprising:

a substrate configured to act as a first electrode of a capacitor;

a resilient element, at least a portion of which is secured at a position spaced from the substrate by a predetermined gap, configured to act as a second electrode of the capacitor; and

a spacing member disposed between the substrate and resilient element supporting a portion of the resilient element at a distance from the substrate greater than said predetermined gap to define an effective electrode area of the capacitor corresponding to an area wherein the substrate and resilient element are separated by said predetermined gap, the effective electrode area changing in response to movement of the resilient element relative to the substrate and resulting in a change in capacitance of the capacitor.

16. The device of claim 15, wherein said spacing member is configured to provide a predetermined tension in the resilient element.

17. The device of claim 15, further comprising a dielectric disposed between the substrate and resilient element to define said predetermined gap, wherein said resilient element is secured at said predetermined gap over a minimum effective electrode area.

18. The device of claim 17, wherein said dielectric comprises a layer disposed on a surface of the substrate and the effective electrode area comprises a variable area of contact between the dielectric material and the resilient element.

15

19. The device of claim 18, wherein the variation in said variable area of contact is effected by a pressure difference across said resilient element.

20. The device of claim 19, wherein said dielectric comprises a layer disposed on a surface of the resilient element, and the effective electrode area comprises a variable area of contact between the substrate and the dielectric material.

21. The device of claim 15, wherein the spacing member is configured to separate a central portion of the resilient element from the substrate.

22. The device of claim 15, wherein the spacing member is configured to separate a peripheral portion of the resilient element from the substrate.

23. The device of claim 15, wherein the spacing member comprises:

a first portion configured to separate a central portion of the resilient element from the substrate; and

a second portion configured to separate a peripheral portion of the resilient element from the substrate.

24. The device of claim 15, wherein said movement occurs in response to a change in force applied to the resilient element, and the change in the capacitance is a function of said change in force.

25. The device of claim 15, wherein said movement occurs in response to a change in pressure acting on the resilient element, and the change in capacitance is a function of said change in pressure.

26. The device of claim 15, wherein said movement occurs in response to change in acceleration acting on the device, and the change in capacitance is a function of said change in acceleration.

27. The device of claim 15, wherein a first surface of the resilient element is configured to be exposed to a first fluid, and the substrate defines an opening so as to expose a second surface of the resilient element to a second fluid.

28. The device of claim 15, wherein said resilient element has a non-uniform thickness.

29. The device of claim 15, wherein the resilient element is configured to provide at least a minimum effective electrode area.

30. The device of claim 15, wherein the spacing member defines a void between the resilient element and the substrate.

31. The device of claim 30, wherein said void comprises a vacuum.

32. The device of claim 30, wherein said void contains a fluid at an initial predetermined pressure.

33. A device comprising:

a substrate configured to act as a first electrode of a capacitor,

a spacing member disposed on the substrate; and

a resilient element configured to act as a second electrode of the capacitor, said resilient element tensioned over said spacing member and secured with the substrate, a portion of said resilient element being spaced from the substrate at a predetermined distance to define an effective capacitance area that varies in response to movement of said resilient element such that a capacitance change effected by said movement may be sustained between said substrate and resilient element.

34. The device according to claim 33, further comprising a dielectric material having a thickness disposed between the substrate and resilient element, wherein said thickness corresponds to said predetermined distance.

16

35. The device according to claim 33, wherein said resilient element is configured to provide at least a minimum effective capacitance area.

36. A device, comprising:

a substrate configured to act as a first electrode of a capacitor;

a resilient element, a first portion of which is spaced from the substrate by a predetermined gap, said resilient element configured to act as a second electrode of the capacitor; and

a spacing member disposed between the substrate and resilient element supporting a second portion of the resilient element at a distance from the substrate greater than said predetermined gap to define an effective electrode area of the capacitor corresponding to said first portion, the spacing member being configured and dimensioned such that the resilient member is tensioned thereover and the effective electrode area changes in response to movement of the resilient element relative to the substrate resulting in a change of capacitance.

37. The device of claim 36, wherein said substrate comprises a dielectric material with an electrode layer deposited thereon.

38. The device of claim 37, wherein a layer of dielectric material is deposited over said electrode layer, said layer of dielectric material having a thickness corresponding to said predetermined gap and said resilient element is secured to the dielectric layer over a minimum effective capacitance area.

39. The device of claim 36, wherein a layer of dielectric material is deposited on the resilient element between said resilient element and the substrate, said layer of dielectric material having a thickness corresponding to said predetermined gap and said dielectric layer is secured to the substrate over a minimum effective capacitance area.

40. A device, comprising:

a substrate configured to act as a first electrode of a capacitor;

a layer of dielectric material disposed on the substrate;

a resilient element disposed on the layer of dielectric material and configured to act as a second electrode of the capacitor; and

a spacing member configured and dimensioned to separate a portion of the resilient element from the layer of dielectric material to define a first contact area between the resilient element and the layer of dielectric material and such that the resilient element is tensioned thereover, the contact area changing in response to movement of the resilient element relative to the substrate and resulting in a change in capacitance of the capacitor.

41. The device of claim 37, wherein said substrate dielectric material is chosen from a group comprising an insulator, an insulator over silicon and SiO₂ over silicon.

42. The device of claim 38 or 39, wherein said layer of dielectric material is chosen from a group comprising silicon, polysilicon, an insulator, an insulator over silicon, an insulator over polysilicon and SiO₂ over silicon.

43. A device, comprising:

a substrate configured to act as a first electrode of a capacitor;

a resilient element, a first portion of which is spaced from the substrate by a predetermined gap, said resilient element configured to act as a second electrode of the capacitor;

17

a layer of dielectric material is disposed on the resilient element between said resilient element and the substrate, said layer of dielectric material having a thickness corresponding to said predetermined gap and being secured to the substrate over said first portion; 5
and
a spacing member disposed between the substrate and said layer of dielectric material supporting a second portion of said layered dielectric material and the resilient element at a distance from the substrate greater

18

than said predetermined gap to define a minimum effective electrode area of the capacitor corresponding to said first portion, the spacing member being configured and dimensioned such that the resilient member is tensioned thereover and the effective electrode area changes in response to movement of the resilient element relative to the substrate resulting in a change of capacitance.

* * * * *